

## **DSL on line 3**

If you are a DSL (Digital Subscriber Line) customer, you may experience interference with the advanced features of this 1040/1070/1080 telephone.

The features (intercom, hold, line privacy, etc.) on this unit, work by sending a data signal across line 1. This data signal is sent at some of the same frequencies as those your DSL signal transmits at. Microfilters are used to block the High Frequency DSL signals from being transmitted through your telephones (so you do not hear the high frequency "squeal" as with fax tones).

These same microfilters that may have been installed for the DSL line will unfortunately also block the intercom signal from being sent between your system phones. Therefore, the features on this unit may not work properly when DSL filters are installed on L1/L2 of your home or business environment.

If you have at least 3 lines and DSL is currently located on Line 1 or Line 2. You can simply switch Line 1/Line 2 with Line3/Line 4 jacks in the back of the phone.

If you need the current phone number that is Line 1 to remain Line 1 as your main dial in number, then you will need to contact the company that provides your DSL and ask them to switch the dsl to Line 3 or 4.

This is the easiest solution. If DSL is working on Line 3 or Line 4, it will not interfere with the advanced features of the phone that work over Line 1.

**Note: If you are moving the DSL to Line3/Line 4 and you have both lines, you will need to use a "2 line DSL filter". These filters may be available through the company that provides your DSL service or they can be purchased at most electronics stores.**

**Note: See Diagram below**

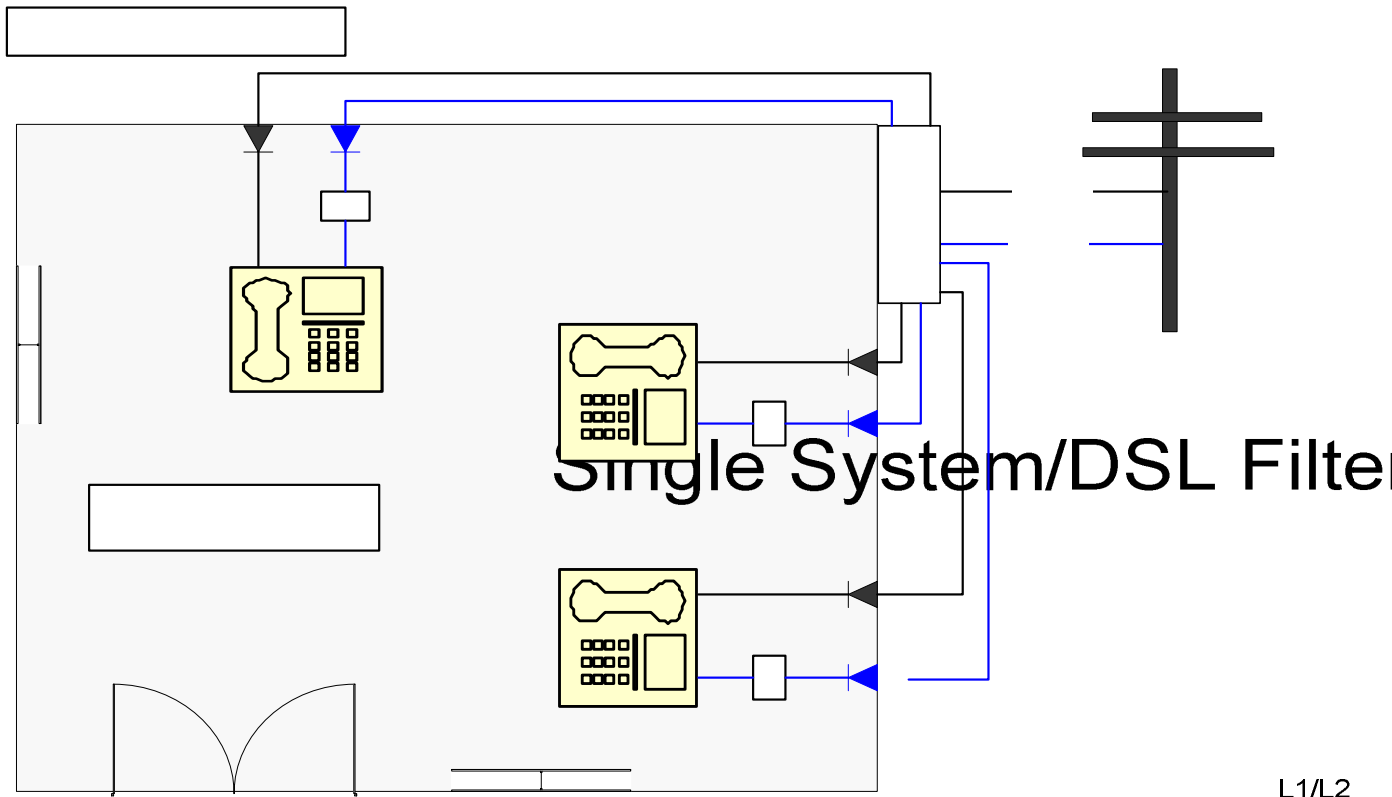

L1/L2

Ext.

Home Run Wi